

17220: Blower Stand Assembly Instructions

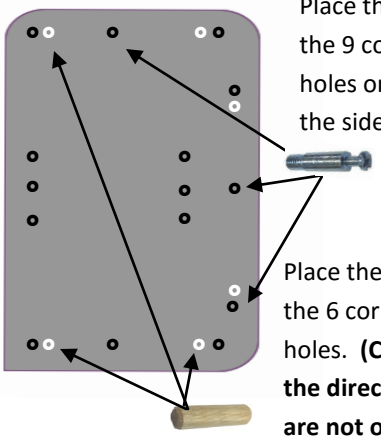

Place the cam lock bolt in the 9 corresponding black holes on the outer edge of the side board.

Place the wooden dowels in the 6 corresponding white holes. **(Colors only apply to the directions, they are not on the boards)**

1

Repeat the previous steps for the second side board. Add the shelf pins to the six holes in the middle on either side.

Repeat the steps for placing the cam lock bolts and dowels in their corresponding color holes on the front board.

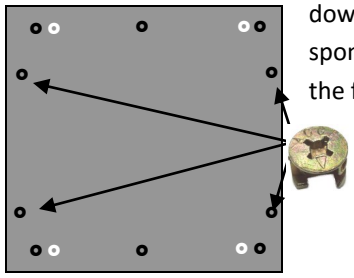

Place the cam locks in the 4 holes near the corners.

2

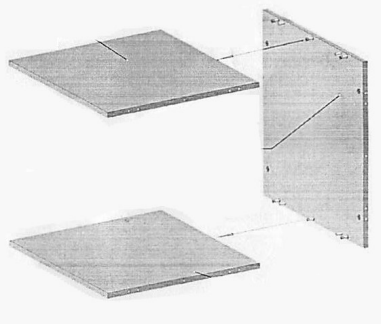

Repeat the previous steps to add the cam locks and dowels to the top and bottom boards. Add the top and bottom boards to the front board as shown, using the cam locks and dowels.

The bottom board will have white plastic inserts in the bottom where the screws for the caster wheels

3

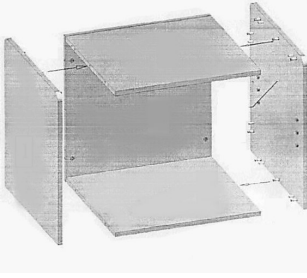

Add the sides to the top, bottom, and front.

The one square corner of each side should be at the bottom. Both rounded corners should be at the top.

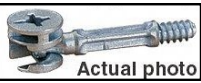

Use a large Philips head screwdriver to lock the cam locks.

4

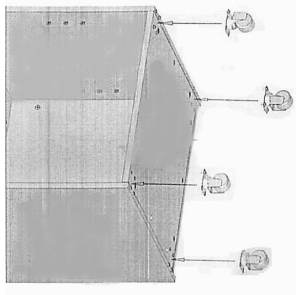

Add the caster wheels to the bottom of the cabinet, using the Philips head screws and screwing them into the white plastic inserts.

5

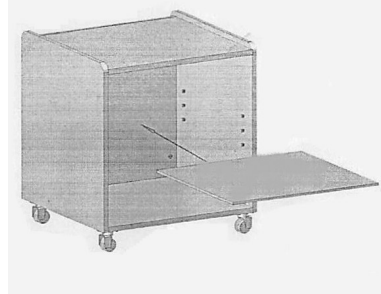





Place the cabinet on its wheels and insert the shelf so that it rests on the shelf pins. The shelf can be adjusted to 3 different positions.







6



Back View

Front View

-  x 2—Side boards. Will have 3 rounded corners and 1 90° corner
-  x 2—Top and bottom boards, the bottom will have white plastic inserts for the caster wheel screws.
-  x 1—Front, will be the larger of the square boards.
-  x 1—Shelf, smallest of the square boards

-  x 27 Wooden Dowels
-  x 12 Shelf Pins
-  x 28 Cam Locks
-  x 28 Cam Lock Bolts
-  x 16 Philips Head
-  x 4 Caster Wheels

There may be extra dowels, cam locks, cam lock bolts, and Philips head screws at the end of the project.